



 **LAYZE**™
SYSTEMS
MODULAR SOLUTIONS FOR OUTDOOR SPACES

SHADEFLA
LIVE OUTDOORS · STAY SHADED

561 NE 79th Street, Suite 330
Miami, Florida 33138
(305) 759-7423

WELCOME INTO
THE NEW ERA
OF LUXURIOUS
OUTDOOR LIVING
AND RELAXATION

WWW.LAYZESYSTEMS.COM

TABLE OF CONTENTS

THE LAYZE WAY	3
MIAMI-DADE N.O.A.	4
THE ADVANTAGES OF MODULAR SYSTEMS	5
MODULAR TERRACE SYSTEMS	6
THE "SLIMLITE" AWNING	8
THE "CANTILUX" AWNING	10
LAYZE RAILINGS	12
LAYZE FENCE	18
LAYZE ESTHEC	20
"COVE" CABANAS	22
OUTDOOR FURNITURE	26
THE "SOLITE" UMBRELLA	28
LAYZE PERGOLA	30
PRODUCT SUMMARY	32



THE LAYZE WAY

Welcome into the new era of luxurious outdoor living, and relaxation. From the Sunshine State, where the uninhibited beauty of the tropical landscapes meets modern art and architecture, comes **Layze Systems™** – a company fully dedicated to transcending your outdoor leisure experience with its revolutionary new modular systems inspired by the marine technology, contemporary design and the passionate outdoor lifestyle of South Florida.

After a decade of engineering and fine-tuning led by the company's founder, Orlando (Orly) Gonzalez and co-founder, Alvaro Cordovez, **Layze Systems™** has finally unveiled its new and unique way to build lavish, fully customizable outdoor living spaces. By integrating the versatility of modular assembly with the elegance of modern design, **Layze Systems™** has put together the ideal shade and comfort collection for your every outdoor need, complete with incredible structural flexibility and exemplary use of materials that can accommodate any setting of your desire.

Layze Systems™ is proud to be the world's first manufacturer of fully-modular, **Miami-Dade NOA-Certified** awnings and terrace canopies that are both patented and made in the USA. **Layze Systems™** available products currently include a variety of modular canopy systems and luxury cabanas, while our future (soon to be available) products include modular awnings, interior/exterior railings, blinds, sunshades and furniture. With every new creative mind joining on board the company, **Layze Systems™** is constantly growing its line of products and expanding its reach to new customers around the globe, thus enabling everyone to discover a new level of comfort and style through the state-of-the-arts modular outdoor-living systems.



MADE IN USA
GUARANTEED
QUALITY



USA PATENTED
REVOLUTIONARY
DESIGN



MIAMI-DADE
N.O.A.
CERTIFIED



FULLY MODULAR
HASSLE-FREE
ASSEMBLY

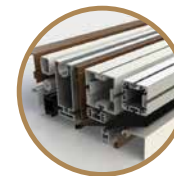

POWDER COATING
MARINE-GRADE
DURABILITY

MIAMI-DADE N.O.A.

UP TO 105 MPH WIND RESISTANCE

The Miami-Dade Notice of Acceptance (NOA) is a product approval certification designed to assure that a product has been reviewed by structural engineers for impact and wind resistance and was found to meet the code criteria in the High Velocity Hurricane Zone (HVHZ).

International Building Code:

Layze systems™ modular awning and terrace canopy variations meet the IBC's wind load and live load requirements as specified in chapter 16 of the code.



N.O.A. CERTIFIED PRODUCTS:

Luxur Canopy and **SlimLite** Awning concepts were first introduced by **Easy Awnings Systems Inc.** (now known as **Layze Systems™**) in 2012. Since then, these state-of-the-art modular designs are the only fully-modular shade systems that have been granted a Miami-Dade NOA product certification for proving to offer unparalleled resilience in an event of a major storm or hurricane. While both **Luxur** and **SlimLite** can be customized to meet virtually any size and slope desired, the following assembly guidelines must be observed in order to fully comply with the product's NOA criteria.

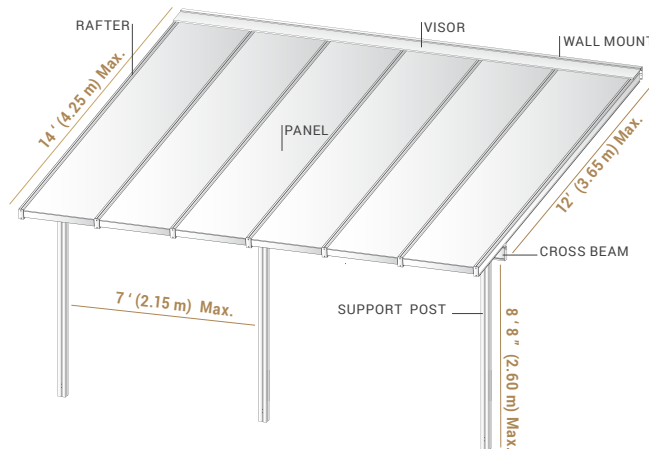
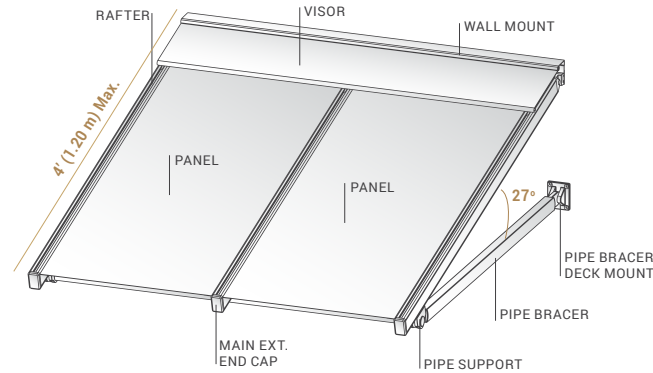

N.O.A. COMPLIANCE REQUIREMENTS FOR SLIMLITE AWNING:

N.O.A. CERTIFICATION #: 13-0422.14

- Awning must be fastened directly onto the main building structure.
- Max. building height to which awning can be fastened to: **60 ft (18.30 m)**
- Max. awning projection from building wall: **4 ft (1.20 m)**
- Min. awning roof slope: **27° degrees**
- Fabric panels shall be removed in the event of winds over **105 mph (170 km/h)**

N.O.A. COMPLIANCE REQUIREMENTS FOR LUXUR CANOPY:

N.O.A. CERTIFICATION #: 13-0430.13

- Canopy must be fastened directly onto the main building structure.
- Maximum building height to which canopy can be fastened to: **60 ft (18.30 m)**
- Canopy total projection from building wall: **14 ft (4.25 m)**
- Max. span from building wall to canopy posts: **12 ft (3.65 m)**
- Min. canopy roof slope: **7° degrees**
- Max. spacing between canopy posts: **7 ft (2.15 m)**
- Max. height of canopy posts: **8'-8" (2.60 m)**
- Fabric panels shall be removed in the event of winds over **105 mph (170 km/h)**

THE ADVANTAGES OF MODULAR DESIGN

DESIGN FLEXIBILITY

With the versatility of our modular systems and a wide array of materials and colors to choose from, you get unlimited customization options and the ability to build your ideal design in just minutes. Our modular installations can be easily and seamlessly adjusted to fit any unique space by extending or reducing the panels and modular components.

FAST AND EASY ASSEMBLY

Layze Systems™ products are made to be easily installed and adjusted to any size needed without frame welding, heavy lifting or canvas stretching. Extensive testing has proven that our modular systems are easy to work with, so much that virtually anyone with basic home tools and experience can assemble them.

CONTEMPORARY LOOK

While providing hundreds of customization options, all **Layze Systems™** products maintain a unified visually impacting style that is attributed to the minimalist stream-line approach that goes into designing fully modular systems. Our products attune to all modern architecture styles and also give an avant-garde twist to more traditional structures.

COST AND ENERGY EFFICIENT

Layze Systems™ products are engineered to consume less energy and produce virtually no waste during the process of their manufacturing, while maintaining their superb quality and durability. Any scraps or cut-off pieces are recycled, thus making our modular outdoor products environmentally friendlier than other custom made installations.

AFFORDABLE LUXURY

Thanks to the cost effective manufacturing process of our modular products, we were able to upgrade to using superior quality materials, thus adding structural integrity while maintaining competitive market prices.

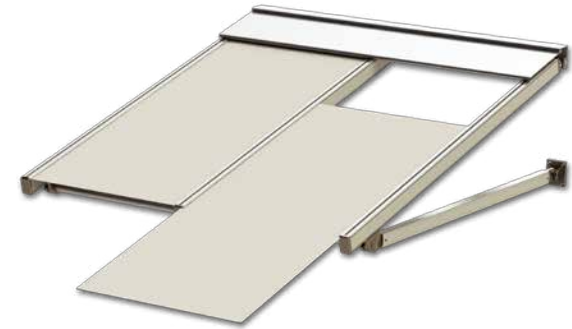

PORTABLE AND SPACE EFFICIENT

- Take your investment with you when you move. Our modular structures can be dismantled just as easy as they are assembled, and arranged in a way that is easy to load and transport.
- Since our modular products are comprised primarily of aluminum extrusions and connectors, our distributors can store more value while using less inventory space.

MODULAR TERRACE SYSTEMS



MIAMI-DADE COUNTY
APPROVED

MODULAR TERRACE SYSTEM

LUXUR

Expand Your outdoor-living area and enjoy the fresh breeze all year round under the shade and shelter of **Layze Systems™** modular terrace canopy - **LUXUR**. While conveying a contemporary look of elegance and luxury, this beautiful terrace system was engineered to serve both residential and commercial structures with the strength and versatility that rivals most other terrace systems of its kind. Using architectural aluminum extrusions and smart connectors, our revolutionary patented frame design allows us to easily configure and customize a terrace structure that will perfectly fit your outdoor space and your unique taste.





PERGOLEAN

FREE-STANDING MODULAR TERRACE SYSTEM

PergoLean is a beautifully balanced free-standing canopy with a sloped (shed style) roof, that is ideal for outdoor spaces where a canopy cannot be mounted directly onto a building structure. This modular pergola creates an inviting shaded enclosure that can be easily adjusted to fit any occasion and setting.



PAVILIA

FREE STANDING GABLE ROOF TERRACE SYSTEM



Expand the patio of your restaurant, hotel entrance or your home's backyard with the incredibly versatile free-standing terrace canopy - **Pavilia**. This contemporary rendition of a traditional gable roof structure will transform any outdoor area into the perfect space for large outdoor events, family gatherings and parties.



FAUX COLUMNS



Adding faux columns to any of the **Layze Systems™** terrace installations will create a more prominent and stately look that will adhere to the unique style of your home or business. These premium quality columns come in a wide variety of shapes, heights and natural colors that can be found on our website www.layzesystems.com

THE SLIMLITE AWNING





SLIMLITE

MODULAR AWNING SYSTEM

Accentuate the exterior of your home or business with **SlimLite** awnings from **Layze Systems™**. This revolutionary awning system has excelled in virtually every category that makes an outdoor-living product great: Modular Versatility, Modern Design, Cost Efficiency and even Hurricane Resistance (which earned it the **Miami-Dade NOA certification**).



EASY ASSEMBLY AND MAINTENANCE

■ **Layze Systems™** products are made to be easily installed and adjusted to any size needed without frame welding, heavy lifting or canvas stretching.

■ Keeping your awning looking new is also made easy. Simply remove the fabric panels or any parts that need to be cleaned and then insert them right back in place.



DESIGN FLEXIBILITY

Our patented method of modular assembly offers our customers great flexibility in design, and allows them to build their ideal outdoor shade at their own pace.

The standard **Slimlite** awning can be easily and seamlessly adjusted to fit any length by extending or reducing panels and section components.

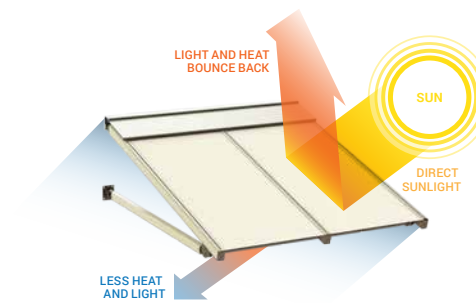

A 'GREEN WAY' TO COOL YOUR INTERIOR

As we strive to operate in an environmentally responsible manner, we also aim to raise our Customers' awareness on how they can become more energy efficient at their place of residence or commercial establishment by using **Layze Systems™** shade products. Studies by the **United States Energy Department** show that awnings, terraces and other shade products can reduce the summer solar heat gain by **65%-77%** - lowering energy consumption and cooling costs by up to **30%**, and thus help home and business owners save hundreds of dollars annually.

THE CANTILUX AWNING



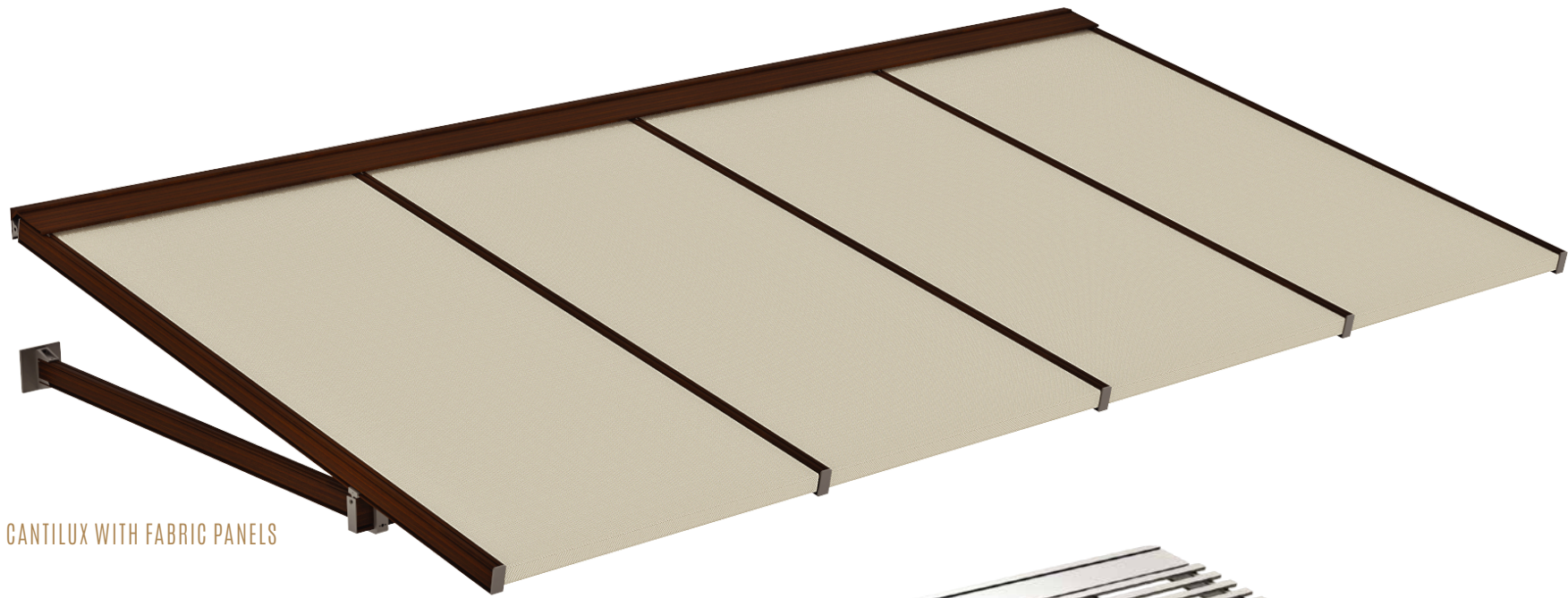

CANTILUX WITH FABRIC PANELS



MODULAR CANTILEVERED AWNING

CANTILUX

Cantilux is a perfect balance of architectural strength and elegance. This cantilevered awning system is designed to offer a greater coverage area while ensuring structural stability and weather resilience. **Cantilux** supports up to 10ft. projection from the building and with endless configuration and color options, this modular awning truly the ideal shade solution for residential patios, commercial plazas, restaurants, hotels and more.



CANTILUX BRISE-SOLEIL (TRELLIS)

LAYZE RAILINGS

Simple to customize and assemble - **Layze Systems™** provides you with the ultimate railing solution that is both luxurious and affordable. Our railings are available in several unique styles, all of which come with standardized modular features and components that can be adjusted to fit all your outdoor space requirements.

THE FRAME

Layze Systems™ modular frames come in four assorted powder-coat finishes: **Monte Carlo, Cairo, Milan** and **Malibu**. When combined with our nickel-plated connectors, these four high performance finishes create an extraordinary modern and luxurious look that compliments most architectural styles and outdoor landscapes.



BASE PLATE



CONCRETE EMBEDDED POST



POST WITH A BASE PLATE

Railing assemblies can be embedded into concrete or secured onto an existing floor using Layze Systems Base Plates that are available in four matching colors.





OPERA

MODULAR GLASS RAILINGS SYSTEM

Opera is an exquisite glass panel railing system, designed to provide maximum support and durability while offering a contemporary minimalist look. This railing system is designed to accommodate both interior and exterior settings, such as hotel pool areas, residential balconies, restaurant patios, and more.

CLASSICAL



MODULAR PICKET RAILINGS SYSTEM

“Classical” is our most popular railing/fencing installation, and is ideal for places that require extra safety and durability. With a wide range of applications this railing system offers all the advantages of a modern system while maintaining the traditional look.



CLASSICAL STAIR RAILING







LOUNGE

MODULAR PICKET RAILINGS SYSTEM

Lounge is a modular railing system with 7/16" laminated glass panel. Its elegance creates an atmosphere of luxury while providing ample support and durability. All railing systems come with optional top rail and grab rail configurations allowing more flexibility in design.

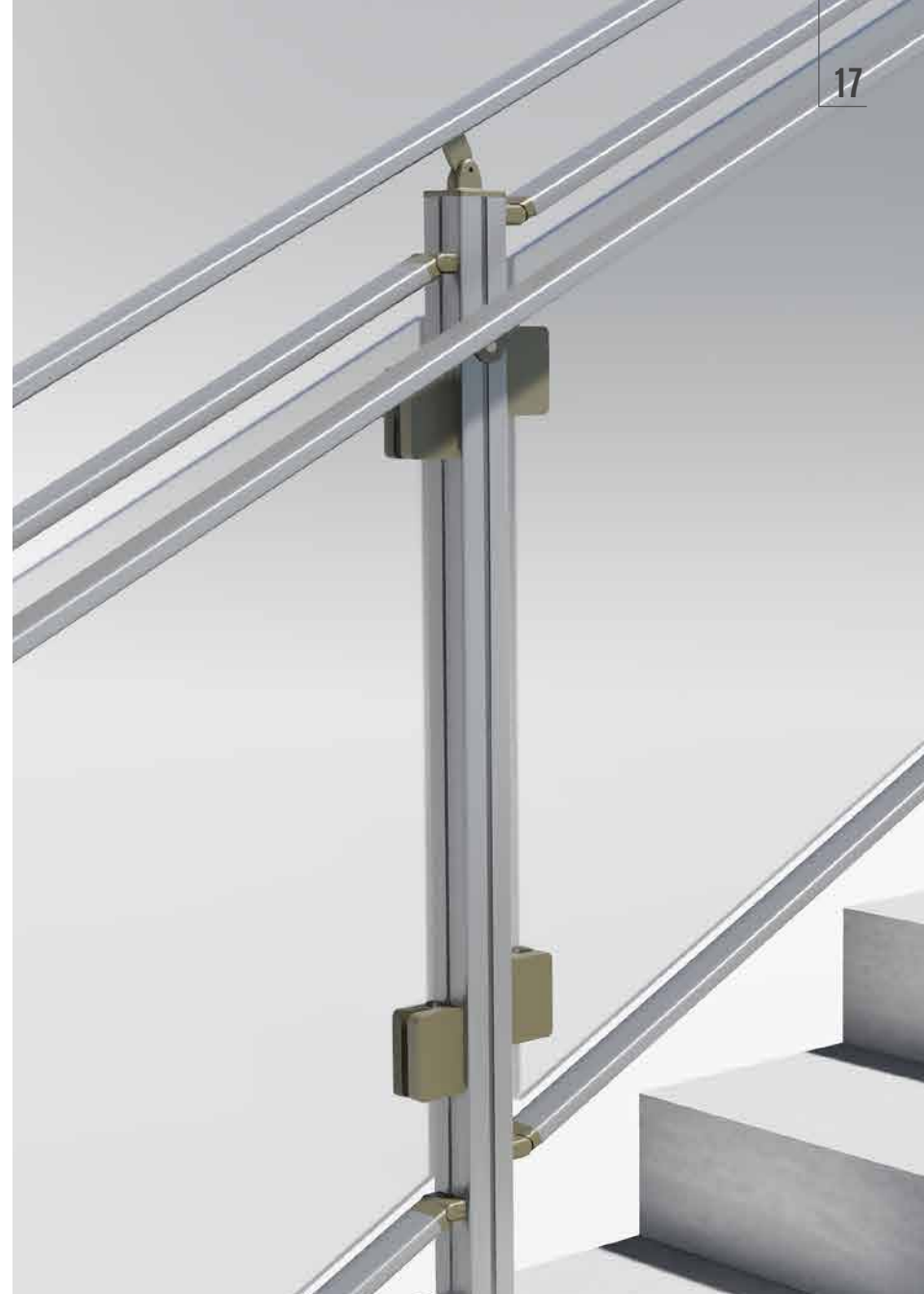





LOUVER

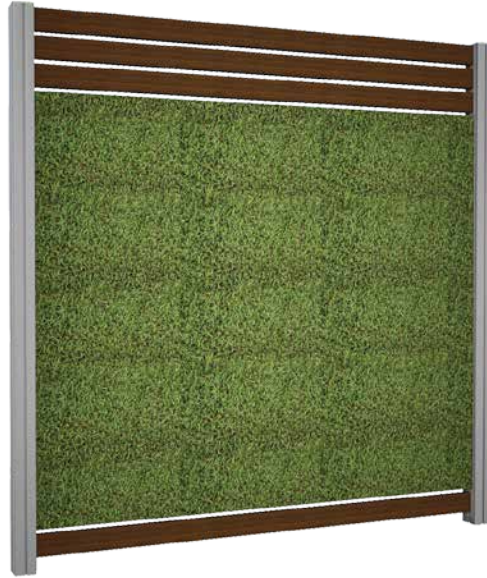

VERTICAL GARDEN



FABRIC SCREEN

LAYZE FENCE

MODULAR FENCE SYSTEM

From louver Fences and vertical gardens to special custom designs, **Layze Systems™** fence assembly is ideal for creating a gorgeous property perimeter with customizable panels that allow you to choose the level of privacy and style that you desire. **Layze Systems™** offers solutions for both commercial and residential fencing, gates and railings using only premium outdoor materials and trained installation professionals.

LAYZE Esthec[®]

MODULAR COMPOSITE DECKING SYSTEM

With over 50 years of excellence in composite products, **Esthec** brings a state-of-the-art decking system that embellishes any outdoor space with its pleasant to the touch surface and contemporary look. This decking system offers unparalleled freedom in application and design with its vast array of structural configurations and a beautiful assortment of natural colors.

Esthec is extremely durable and versatile. It is the ideal solution to any patio decking and even vertical wall paneling for both commercial and residential applications such as: hotels and spa resorts, balconies and pool areas, roof top gardens, yacht docks and more.







"PLAYA" SERIES

COVE

COZY OUTDOOR VENTILATED ENCLOSURE

Escape into a private retreat of luscious relaxation, or treat your guests to a VIP-like hospitality in the luxury and comfort of the **Layze Systems™ Cozy Outdoor Ventilated Enclosure (COVE)**. Whether it is a hotel, restaurant or your own backyard, this exquisite cabana will transform any outdoor leisure, pool-side or dining area into an exotic sheltered oasis made especially for You.

MAKE IT YOUR OWN

Customize your ideal cabana with our wide selection of modular configurations, high-quality materials and fashionable colors to suit your specific needs and create an atmosphere you desire. At every stage of customization the **COVE** offers a complete look and functionality that allows you to design your dream outdoor-living space at your own individual pace.



"PLAYA" SERIES

CUSTOMIZE

Start customizing your unique **COVE** by choosing one of our four assorted heavy-duty aluminum frame colors and the dimensions that you require. The **COVE** is available in standard sizes: 12ft x 12ft, 10ft x 10ft, 8ft x 8ft but can be custom fitted to virtually any size. A free-standing structure can be embedded into a concrete floor or bolted onto an existing floor using base plates.

DEFINE

Floor: Outline the form and add stability to your **COVE** with your choice of Eco-friendly recycled composite decking. This floor is easy to install and requires virtually no maintenance. It is available in a wide array of natural wood finishes and comes with residential and commercial warranty from the manufacturer.

Enclosure: Enhance the look of your **COVE** and create privacy by selecting one of our many side panel, railings and curtain options. This helps you control the amount of sunlight in your cabana, and sets an intimate atmosphere.

PERFECT

Bring your unique cabana design to completion with our beautifully upholstered outdoor furniture. This inviting, easy-to-install, outdoor furniture comes in various configurations, such as sofas, beds, dining sets and more, and can be either free-standing or fixed onto the cabana's main frame, thus fortifying the structure and creating a unified look.



U-SHAPE SOFA



L-SHAPE SOFA



I-SHAPE FACING SOFAS



LOUNGE BED



DINING TABLE & BENCHES



LOUNGE CHAIRS & MIDDLE TABLE



NATU COVE

MODULAR TEPEE CABANA



Natu is a unique modular cabana design that offers intimacy and cozy relaxation while providing ample space for both standing, sitting and laying down. It's exotic yet very practical triangular shape was inspired by native habitats from many parts of the world. The steep slope of the roof allows this cabana to endure harsh rains and even snow while remaining comfortable inside. Like all **Layze Systems™** products, **Natu** comes with a wide range of customization options that include: love-seat and bed furnishing, hundreds of fabric color choices and accessories to make this cabana truly your own.

SOMNI COVE

MODULAR CABANA BED

Somni COVE embodies the desire to seize the relaxing ambiance of nature while indulging in the comfort and shelter of a soft bed. This beautiful cabana will complete any pool-side area or a waterfront view and will invite a sense of luxury and wholeness with its unique yet simple form.

Available in either queen-size, king-size or two twin XL beds; this cabana can fit up to 4 people and can be also adjusted to a custom height. Customization options include: our four assorted aluminum frame finishes, various roof designs, privacy panels, curtains and large selection of outdoor fabric colors for cushions and accent pillows to suit your taste.



ESCAPE INTO THE OPEN.

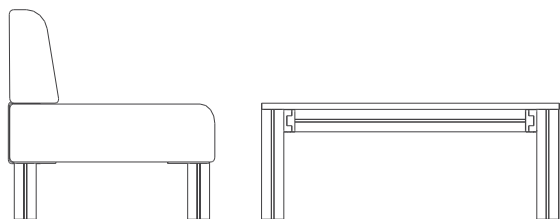

CAPRI LOUNGING SET

Entertain guests or simply relax in the luxury of the coastal-living inspired lounging collection - **Capri** by Layze Systems. This versatile and fully customizable outdoor collection is put together by highly skilled professionals using premium quality marine-grade materials to ensure your comfort and satisfaction for many years to come.

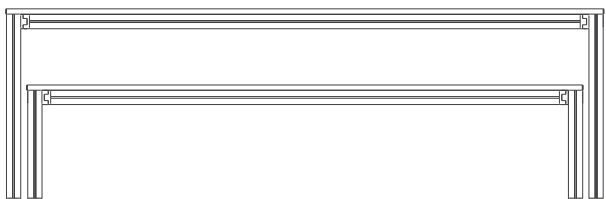

SORRENTO DINING SET

Sorrento captures the tranquil sophistication of alfresco dining by pairing classic coastal top design with a contemporary frame. This highly versatile collection can be customized to perfectly fit in any size space or style and is made easy to clean and maintain. Each set is made with care and attention to details with marine-grade materials to assure aesthetic quality and durability.

THE
SOLLITE
UMBRELLA





SOLLITE

MODULAR UMBRELLA SYSTEM

Layze Systems™ is introducing an entirely new modular umbrella that will transcend the outdoor shade industry with its next generation rig system. With its array of modular functions and the patent pending "touch-up" system, the **SOLLite** umbrella stands in a class of its own.

TOUCH-UP

The patent pending "touch-up" system was designed with the consumer in mind. With a simple gesture of one finger, you can raise or lower your **SOLLite** umbrella at will. Even the largest diameter umbrellas can be lifted and lowered with a minimal effort.

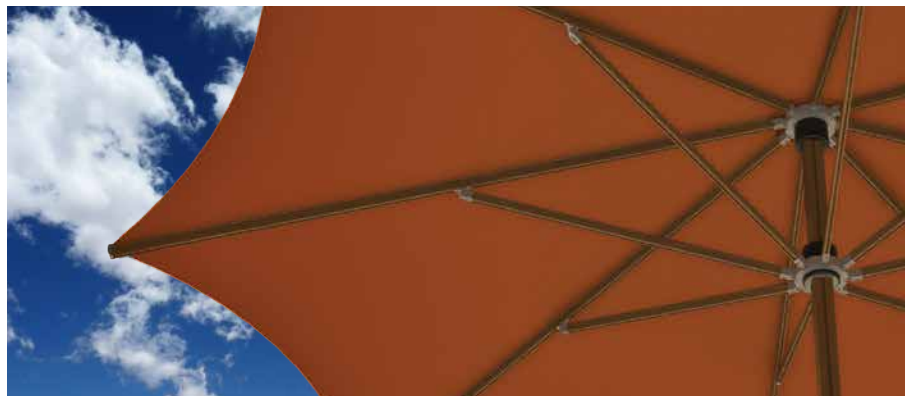

The modular functionality of the **SOLLite** umbrella is so versatile, that a change in fabric color can be made without any professional assistance. All that is needed is a new set of fabric, or a combination of them and you can change the color of your **SOLLite** umbrella to fit your mood. That's not all, the **SOLLite** umbrella can be modified from a Square (Rectangular, 4 panels span) model to Omni (Round, 8 panels span) model in just a few minutes with the right tools and the corresponding fabric.



SQUARE

Style: Signature Collection "Sol"
Frame: Milan (Anodized Aluminum Finish)
Fabric: Hawaii (Yellow)
Base: Round*, Black Plastic Cover

* Square shape base is also available in a variety of colors.



OMNI

Style: Signature Collection "Ash"
Frame: Milan (Anodized Aluminum Finish)
Fabric: Saba (Black)
Base: Round*, Black Plastic Cover



PERGOLA

MODULAR PERGOLA SYSTEM

Layze Systems™ Pergola is designed to offer a modern solution of a traditional design for your outdoor space. This heavy-duty, marine-grade aluminum frame ensures stability, weather resilience and a unique contemporary look you can enjoy for years to come.



SIGNATURE COLLECTION: applies to all LAYZE SYSTEMS™ products



MONTE CARLO

Model: Luxur, Steped end-cap
Frame: Gloss Whites
Fabric: Light Grey



CAIRO

Model: Luxur, Steped end-cap
Frame: Anthrosite
Fabric: Brown



MALIBU

Model: Luxur, Steped end-cap
Frame: Wood Finish
Fabric: Beige



MILAN

Model: Luxur, Steped end-cap
Frame: Anodized Aluminum
Fabric: Light Brown

PRODUCTS SUMMARY

COLORS:

Layze Systems™ four assorted powder-coating frame colors:

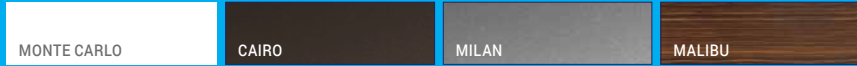

Our Signature Collection as well as hundreds more color options of acrylic outdoor fabrics are provided by



MODULAR TERRACE CANOPY SYSTEMS:



FRAME:

- 4 Assorted powder-coat colors
- Special order powder-coat color available

PANELS:

- Acrylic outdoor fabric collection
- Special order fabrics are available
- Transparent weather resistant vinyl panels
- Die-cut metal mesh panels

ACCESSORIES:

- Faux columns
- Electric wiring for light fixtures
- Mosquito net enclosure
- Post illumination
- Railings and gate
- Panel extension kit

SLIMLITE MODULAR AWNING SYSTEM:

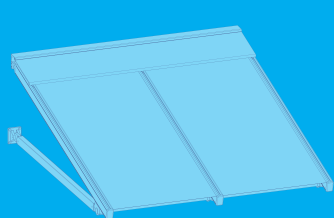

SLIMLITE
(NOA or non-NOA)

FRAME:

- 4 Assorted powder-coat colors
- Special order powder-coat color available

PANELS:

- Acrylic outdoor fabric collection
- Special order fabrics are available
- Transparent weather resistant vinyl panels
- Die-cut metal mesh panels

ACCESSORIES:

- Valance
- Side panels
- Panel extension kit

CANTILUX MODULAR AWNING SYSTEM:

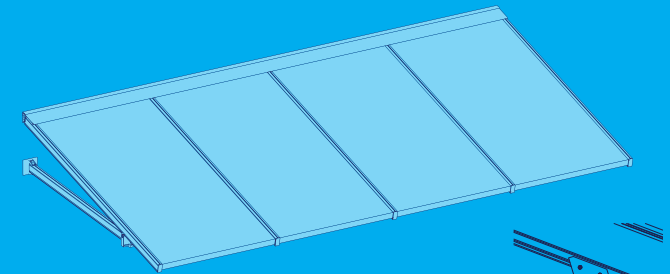

CANTILUX

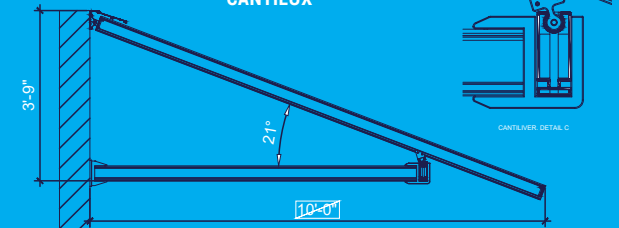

CANTILIVER, MAX ANGLE

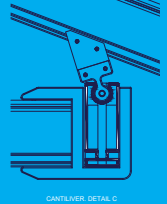

CANTILIVER DETAIL C



CANTILIVER DETAIL D

FRAME:

- 4 Assorted powder-coat colors
- Special order powder-coat color available

PANELS:

- Acrylic outdoor fabric collection
- Special order fabrics are available
- Transparent weather resistant vinyl panels
- Die-cut metal mesh panels

ACCESSORIES:

- Valance
- Side panels
- Panel extension kit
- Electric wiring for light fixtures

LAYZE RAILING SYSTEMS:



CLASSICAL (NOA or non-NOA)

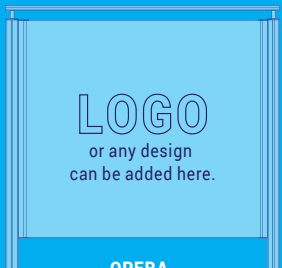

OPERA



LOUNGE

LAYZE FENCE SYSTEMS:

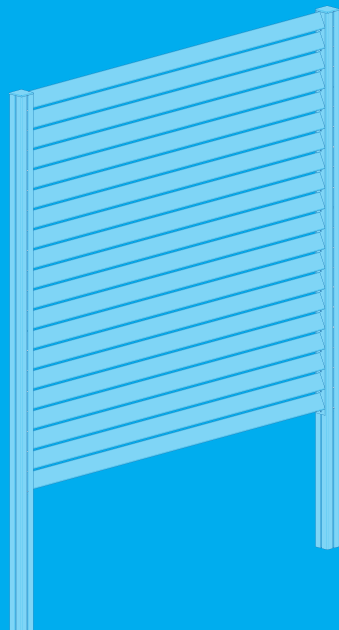

FENCE. SECTION

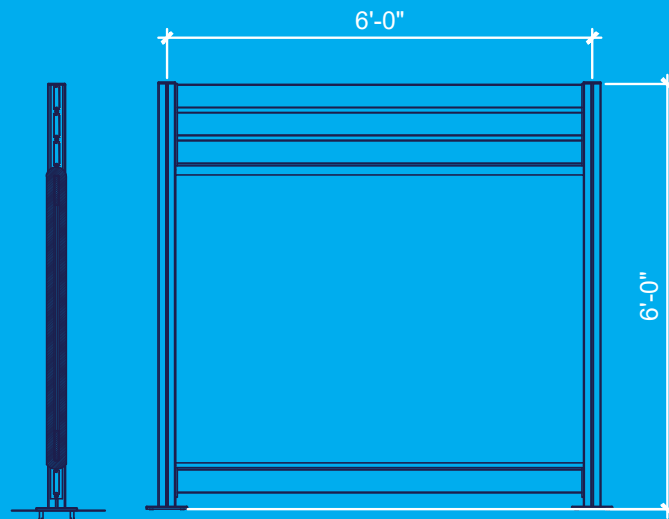

FENCE. FRONT VIEW

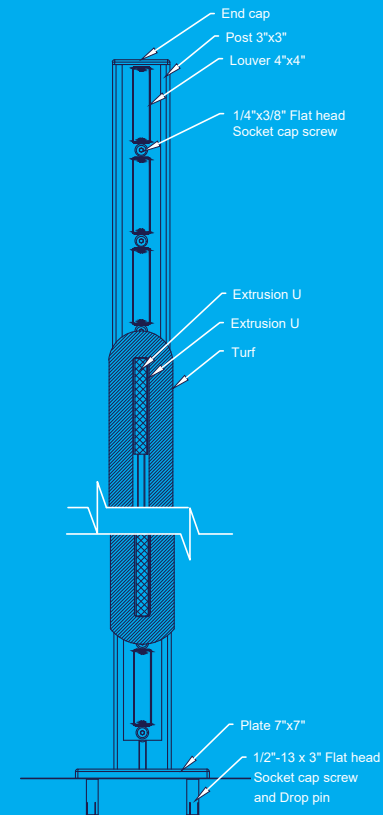
**FRAME:**

- 4 Assorted powder-coat colors
- Special order powder-coat color available
- Stairway configuration
- Optional hand rails attachment
- Base Plates

PANELS:

- 20 Heavy-duty aluminum louvers
- Vertical garden
- Faux turf
- Fabric or vinyl screen
- 7/16" Laminated glass panels
- Die-cut metal mesh panels
- Custom architectural designs

ACCESSORIES:

- Faux columns
- Electric wiring for light fixtures
- Post illumination
- Gate
- Panel extension kit
- Logo placement options available

End cap

Post 3"x3"

Louver 4"x4"

1/4"x3/8" Flat head
Socket cap screw

Extrusion U

Extrusion U

Turf

Plate 7"x7"

1/2"-13 x 3" Flat head
Socket cap screw
and Drop pin

COVE - MODULAR CABANA SYSTEMS:

FRAME:

- 4 Assorted powder-coat colors
- Special order powder-coat color available

ROOF:

- Retractable wave fabric
- Stretched fabric
- Transparent weather resistant vinyl panels
- Die-cut metal mesh panels

FLOOR:

- 6 Assorted recycled composite decking colors
- Special order flooring available

PANELS:

- Curtains (see Playa COVE)
- Railings
- Acrylic enclosure panels
- Die-cut metal mesh panels
- Slatted Panels (see Somni COVE)
- Wave fabric panels (see Nami COVE)
- Sliding panels

ACCESSORIES:

- Faux columns
- Electric wiring for light fixtures
- Post illumination
- Accent pillows



Playa COVE



Somni COVE



Natu COVE

SOLLITE - MODULAR UMBRELLA

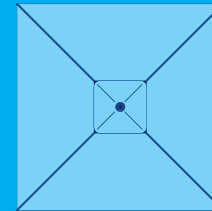

SQUARE

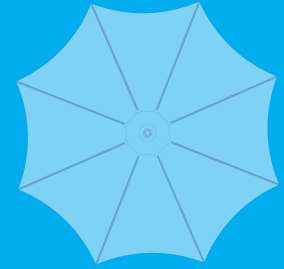

OMNI

FRAME:

- 4 Assorted powder-coat colors
- Special order powder-coat color available

ACCESSORIES:

- Electric wiring for light fixtures
- Post illumination
- Logo placement options available

PANELS:

- Acrylic outdoor fabric collection
- Special order fabrics are available

BASE:

- Round, in multiple colors
- Square, in multiple colors

LAYZE BRISE-SOLEIL

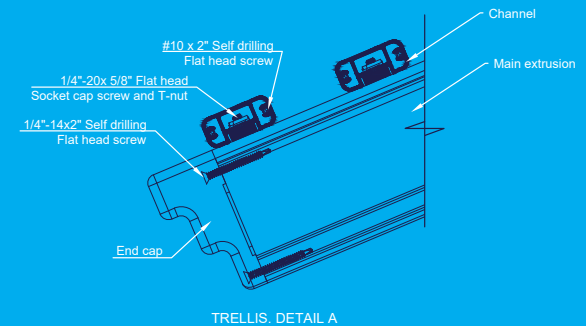
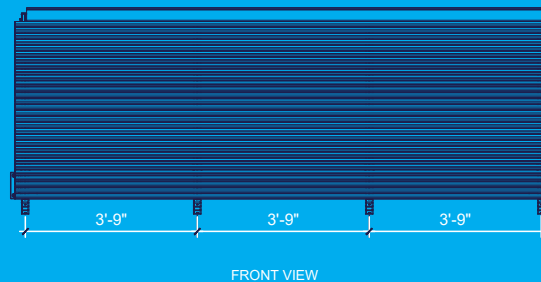
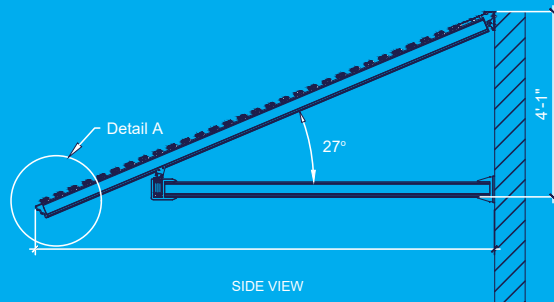

“CAPRI” LOUNGING FURNITURE COLLECTION

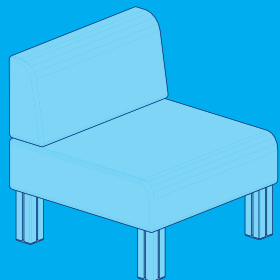

CHAIR

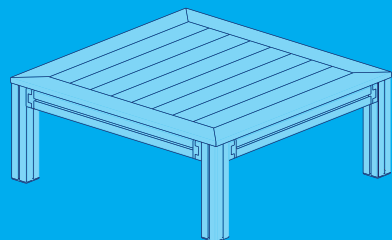

COFFEE TABLE

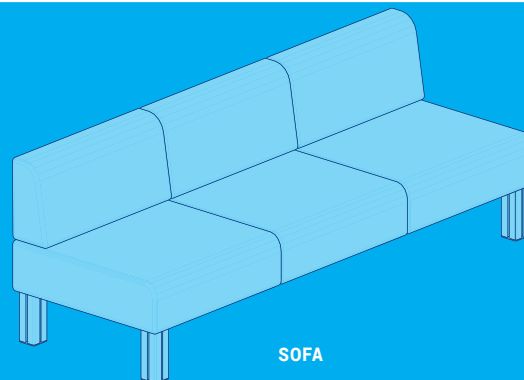

SOFA

“SORRENTO” DINING COLLECTION

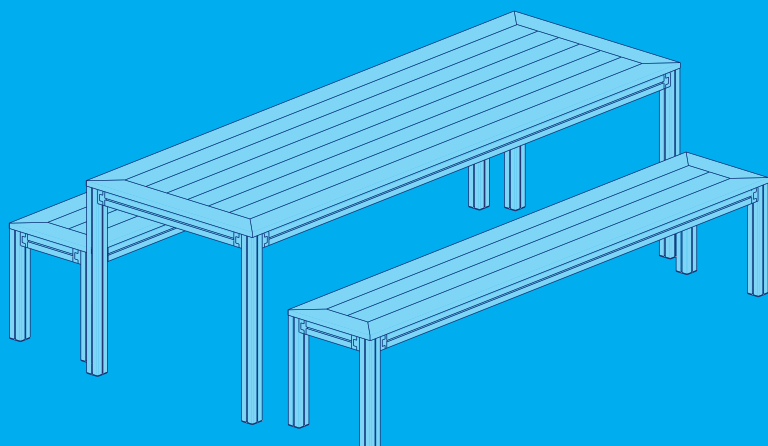

FRAME:

- 4 Assorted powder-coat colors
- Special order powder-coat color available

TABLE TOP:

- Any custom size and configuration is available
- Glass panel
- Die-cut metal mesh panels
- Slatted planks

ACCESSORIES:

- Accent pillows
- Illumination

FURNITURE COLOR COLLECTIONS (personalized color selection available)

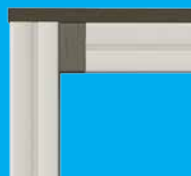

Monte Carlo

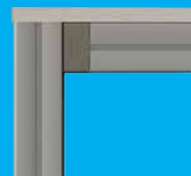

Milan



Cairo



Malibu

*The **Layze** way of life.*



 WEBSITE:
WWW.LAYZESYSTEMS.COM

 HQ ADDRESS:
3480 NW 21ST ST. MIAMI, FL 33142

 TOLL FREE:
1(844)BE-LAYZE (235-2993)

 MIAMI LOCAL:
(786) 465-2864

 EMAIL:
INFO@LAYZESYSTEMS.COM

 FAX:
(305) 901-2122

Disclaimer: Although all product renderings and information contained in this brochure are believed correct at the time publication, this brochure is intended for general marketing purposes only; and should not be relayed upon by any person as being complete or accurate. No employee, agent or other representative of **Layze Systems Inc.** will accept any liability that may arise from reliance on the content of this brochure. **Layze System Inc.** reserves the right to make changes to its publications and products, without notice or obligation, in prices, specifications, colors and materials. All photography attributions can be found on our website. WWW.LAYZESYSTEMS.COM

